



Fuller® Heavy Duty Transmissions

**Roadranger®**

More time on the road \*

### Video Instruction Available

Instructional videos are available for download at no charge at [roadranger.com](http://roadranger.com)

Videos are also available in DVD format for \$20. To order, call 1-888-386-4636. Ask for item # RRSD0002

# Driver Instructions

---

## Fuller Heavy Duty Transmissions

### TRDR0550

### September 2007

RTLO-11610B	RTLO-18610B-T2
RTLO-11610B-T2	RTLOF-11610B
RTLO-12610B	RTLOF-11610B-T2
RTLO-12610B-T2	RTLOF-12610B
RTLO-13610B	RTLOF-12610B-T2
RTLO-13610B-T2	RTLOF-13610B
RTLO-14610A	RTLOF-13610B-T2
RTLO-14610B	RTLOF-14610B
RTLO-14610B-T2	RTLOF-14610B-T2
RTLO-15610B	RTLOF-15610B
RTLO-15610B-T2	RTLOF-15610B-T2
RTLO-16610B	RTLOF-16610B
RTLO-16610B-T2	RTLOF-16610B-T2
RTLO-17610B	RTLOF-17610B
RTLO-17610B-T2	RTLOF-17610B-T2
RTLO-18610B	RTLOF-18610B

# *Introduction*

## Warnings and Cautions



Read the entire driver instructions before operating this transmission.

Set the parking brakes before starting a vehicle, always be seated in the driver's seat, move the shift lever to neutral, and depress the master clutch.

If engine cranks in any gear other than neutral or without the master clutch depressed, service your vehicle neutral safety start circuit immediately.

Before working on a vehicle or when leaving the cab with the engine running, place the transmission in neutral, set the parking brakes, and block the wheels.

Do not release the parking brake or attempt to select a gear until the air pressure is at the correct level.

When parking the vehicle or leaving the cab, always place the shift lever in neutral and set the parking brakes.

If your vehicle is equipped with a remote throttle, before operation, the transmission must be in neutral.

**TOWING:** To avoid damage to the transmission during towing, disconnect the driveline.

# Table of Contents

## Introduction

Warnings and Cautions .....	i
Identification Tag .....	1
Model Nomenclature .....	2
Purpose .....	3
General Information .....	4

## Transmission Operation

Shift Knob .....	6
Initial Start Up .....	7
Types of Super 10 Shifts .....	8
Shift Procedures - Button Only Shift .....	9
Shift Procedures - Combination Button and Lever Shift .....	11
Shift Procedures - Lever Only Shift .....	12
Double-Clutching Procedure .....	14
Typical Transmission Shift Points for a Super 10 in an ON Highway Application .....	15
Reverse Operation .....	16
Range Shift .....	17
Clutch Brake .....	18
How to get the most from your Super 10 .....	19
Transmission Do's and Don'ts .....	20

## Super 10 Top 2

Basic Operation and Overview of Super 10 Top 2 .....	21
Super 10 Top 2 Upshift Procedure.....	22
Super 10 Top 2 Downshift Procedure .....	23
Super 10 Top 2 Driving Tips .....	24
Top 2 System Problem.....	25

## Service & Maintenance

Lubrication Information .....	26
Preventive Maintenance .....	29

## Reference

Definitions/Glossary of Terms for Transmission Operation .....	31
---	----

# Introduction

## Identification Tag

### Transmission Tag and Location

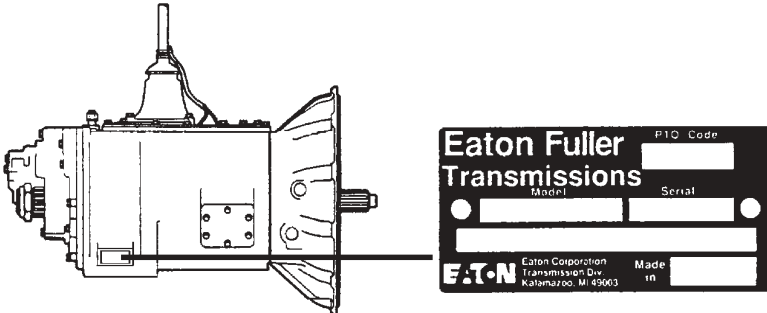

DO NOT REMOVE OR DESTROY THE TRANSMISSION IDENTIFICATION TAG.

Transmission model designation and other transmission identification information are stamped on the transmission tag. To identify the transmission model designation and serial number, locate the tag on the transmission and then locate the numbers as shown (example: RTLO-14610B).

Record transmission identification data. Have these reference numbers handy when ordering replacement parts or requesting service information.

## Model Nomenclature

The model number gives basic information about the transmission. Use this number when calling for service assistance or replacement parts.

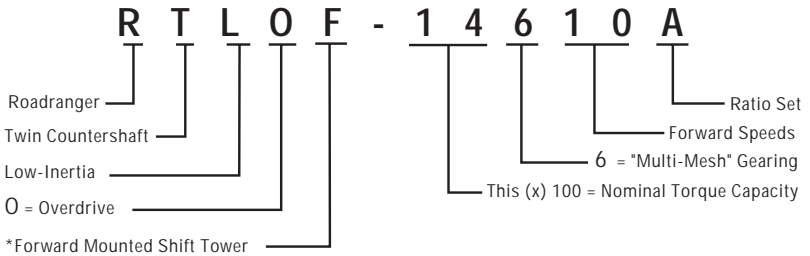

### Serial Number

The serial number is the sequential identification number of the transmission. Before calling for service assistance, write the number down. It may be needed.

### Bill of Material or Customer Number

This number may be located below the model and serial numbers. It is a reference number used by Eaton®.

# *Introduction*

## **Purpose**

This manual is designed to provide detailed information necessary for the proper driving techniques of the Eaton® Fuller® transmissions listed on the cover.

## **How to Use this Manual**

Driver instructions are divided into two sections: Transmission Operation and Service and Maintenance. Transmission Operation contains information on driving techniques along with shift patterns. Service and Maintenance contains information items that deal with basic service and maintenance; such as, identification tags and lubrication information.

## General Information

Congratulations on your purchase of a Super 10 Transmission. This new generation transmission may be different from any other transmission you have operated.

In the Super 10, half of the ten speed ratios are shifted with the shift lever while the other half are shifted by moving the shift button. Button shifts require the driver to raise or lower the engine RPM the same amount as a lever shift.

To successfully operate this or any transmission, the driver must be aware of the characteristics of today's diesel engines. Today's engines:

- Produce horsepower and torque at a lower RPM
- Operate at a lower RPM
- Are governed at a lower RPM
- Decelerate slower

By understanding these engine characteristics and knowing that the transmission works as a partner with the engine, the driver can successfully manage the powertrain package to achieve the best vehicle performance and fuel economy.

In a Super 10, this means that a driver should remember to shift at a lower RPM and allow enough time for the engine speed to decrease sufficiently for the next higher gear.

By shifting with the proper technique, the driver can fully appreciate the ease and simplicity the Super 10 offers.

# Introduction

## Shift Pattern Diagram

A shift pattern diagram should be in your vehicle. If it has been lost, a replacement may be obtained by writing to:

Eaton Corporation  
**Truck Components**  
Global Marketing Services  
P.O. Box 4013  
Kalamazoo, MI 49003  
[www.roadranger.com](http://www.roadranger.com)

Please specify shifting controls used and transmission model number when making request.

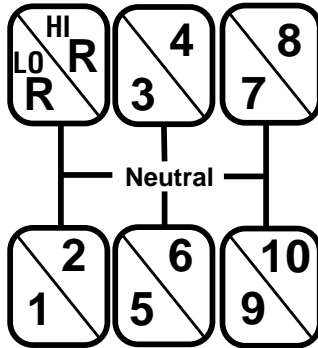

# Transmission Operation

## Shift Knob

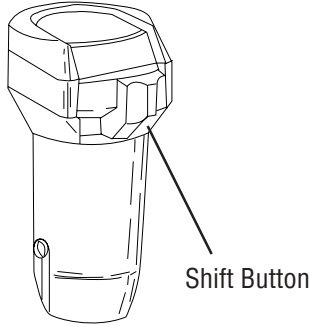

## Shift Button Forward

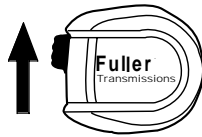

Gears 2, 4, 6, 8, 10  
when button is forward

## Shift Button Rearward

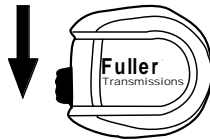

Gears 1, 3, 5, 7, 9  
when button is rearward

# Transmission Operation

## Initial Start Up

### Special Instructions



**WARNING:** Before starting a vehicle always be seated in the driver's seat, move the shift lever to neutral, and set the parking brakes.



**CAUTION:** Before moving a vehicle, make sure you understand your shift pattern configuration. A shift label should be in your vehicle's cab. If not, refer to General Information to order one.

1. Make sure the lever is in neutral and the parking brakes are set.
2. Depress the clutch pedal, turn on the key switch, and start the engine.
3. Allow the vehicle air pressure to build to the proper operating pressure (90-120 PSI). Refer to your "Operating or Service Manual" supplied with the truck.
4. Depress the brake pedal.
5. Depress the clutch pedal to the floor to contact the clutch brake.
6. Move the shift lever to the desired starting gear.
7. Release the parking brakes on the vehicle.
8. Slowly let up on the clutch pedal.
9. When the clutch is fully engaged, apply the accelerator.

## **Types of Super 10 Shifts**

There are three different types of shifts used with the Super 10 transmission:

### **Button Only Shift**

This is a gear ratio change that occurs by moving the shift button.

### **Combination Button/Lever Shift**

This is a gear ratio change that occurs by moving both the shift button and shift lever.

### **Lever Only Shift**

This shift occurs when the shift lever is moved without moving the shift button. It results in a skip of a full gear ratio and should only be used when the vehicle is bobtail or lightly loaded.

**Note:** Button Only shifts and Combination Button/Lever shifts are both full gear changes. Lever only shifts skip a gear.

# Transmission Operation

## Shift Procedures - Button Only Shift

### Upshift

Use upshift for gear changes 1st to 2nd, 3rd to 4th, 5th to 6th, 7th to 8th, and 9th to 10th.

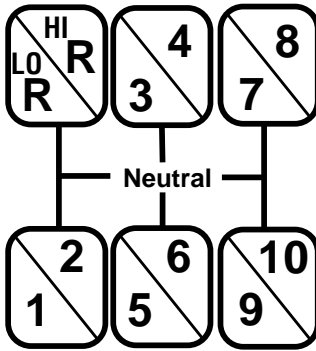

1. Accelerate through the current gear, when the next gear is desired.
2. Preselect by moving the shift button forward. Immediately break torque by releasing the throttle or depressing the clutch pedal. Then allow the engine RPM to decrease to provide synchronous for the next desired gear.
3. The shift will complete when the engine RPM has decreased to the proper speed.

**TIP:** Use the tachometer to determine when the shift completes.

# Transmission Operation

## Downshift

Use downshift for gear changes 10th to 9th, 8th to 7th, 6th to 5th, 4th to 3rd, and 2nd to 1st.

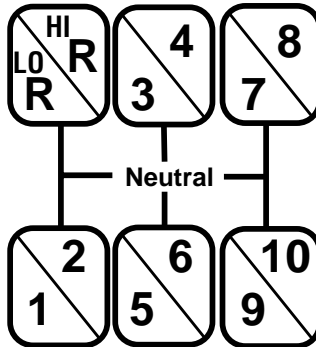

4. As the vehicle decelerates, and a downshift is desired\*...

**Note:** \*Do not attempt a downshift at too high of an engine speed (generally above 1400 RPM).

5. With the throttle still applied, preselect by moving the shift button rearward and immediately breaking torque by releasing the throttle or depressing the clutch pedal. Increase engine RPM to provide synchronous for the desired gear.
6. The shift will complete when the engine RPM has increased to the proper speed.

# Transmission Operation

## Shift Procedures - Combination Button and Lever Shift

### Upshift

Use upshift for gear changes 2nd to 3rd, 4th to 5th, 6th to 7th, and 8th to 9th.

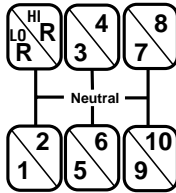

1. Accelerate through the current gear, when the next gear is desired.
2. Preselect by moving the shift button rearward, immediately break torque by releasing the throttle and depressing the clutch pedal. Then using proper Double-Clutching Procedure on page 14, move the shift lever to the next desired gear position.

### Downshift

Use downshift for gear changes 9th to 8th, 7th to 6th, 5th to 4th, and 3rd to 2nd.

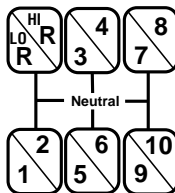

3. As the vehicle decelerates, and a downshift is desired\*...

**Note:** \*Do not attempt a downshift at too high of an engine speed (generally above 1400 RPM).

4. With the throttle still applied, preselect by moving the shift button forward, immediately break torque by releasing the throttle and depressing the clutch pedal, then use proper Double-Clutching Procedure on page 14, move the shift lever to the next desired gear position.

# Transmission Operation

## Shift Procedures - Lever Only Shift

Lever Only Shift is used for skipping a full gear ratio when the vehicle is lightly loaded or bobtail.

### Upshift

Upshift with the shift button rearward - 1st to 3rd, 3rd to 5th, 5th to 7th and 7th to 9th.

Upshift with the shift button forward - 2nd to 4th, 4th to 6th, 6th to 8th, and 8th to 10th.

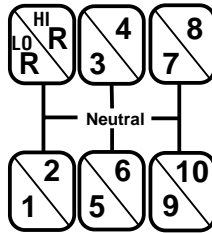

1. Accelerate through the current gear, when the next gear is desired.
2. Break torque by releasing the throttle and depressing the clutch pedal, then using normal Double-Clutching Procedure on page 14, move the shift lever to the next desired gear position.

**Note:** Lever Only shifts skip an entire gear ratio and will require the engine RPM to decrease twice the amount of a normal shift.

# Transmission Operation

## Downshift

Downshift with the shift button rearward - 9th to 7th, 7th to 5th, 5th to 3rd, and 3rd to 1st.

Downshift with the shift button forward - 10th to 8th, 8th to 6th, 6th to 4th, 4th to 2nd.

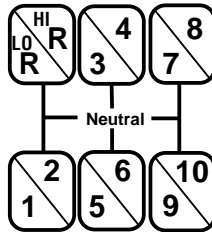

3. As the vehicle decelerates and a downshift is desired\*...

**Note:** \*Do not attempt a lever only downshift at too high of an engine speed (generally above 1000 RPM).

4. Break torque by releasing the throttle and depressing the clutch pedal, then using normal Double-Clutching Procedure on page 14, move the shift lever to the next desired gear position.

## Double-Clutching Procedure

### Special Instructions

Purpose:

- a. To break torque to allow the transmission to come out of gear, and...
- b. To disengage the engine from the transmission when shifting into gear.

### Procedure -

1. Release accelerator.
2. Depress clutch pedal slightly to break torque enough to move the shift lever to neutral.

**Note:** Avoid depressing the clutch pedal too far and contacting the clutch brake.

3. When the shift lever is in neutral, let up on clutch pedal.

**Note:** Engaging the clutch with the shift lever in the neutral position connects the transmission input gearing to the engine. This allows the operator to speed up or slow down the transmission input gearing to properly match the desired gear speed to the current road speed.

- a. For upshifts - allow engine RPM to decrease to match road speed.
  - b. For downshifts - increase engine RPM to match road speed.
4. At the correct engine RPM, depress the clutch pedal slightly and **at the same time**, move the shift lever into the desired gear.
  5. Let up on the clutch pedal and apply accelerator.

# Transmission Operation

## Typical Transmission Shift Points for a Super 10 in an On-Highway Application

Vehicle Speed vs. Engine Speed & Gear

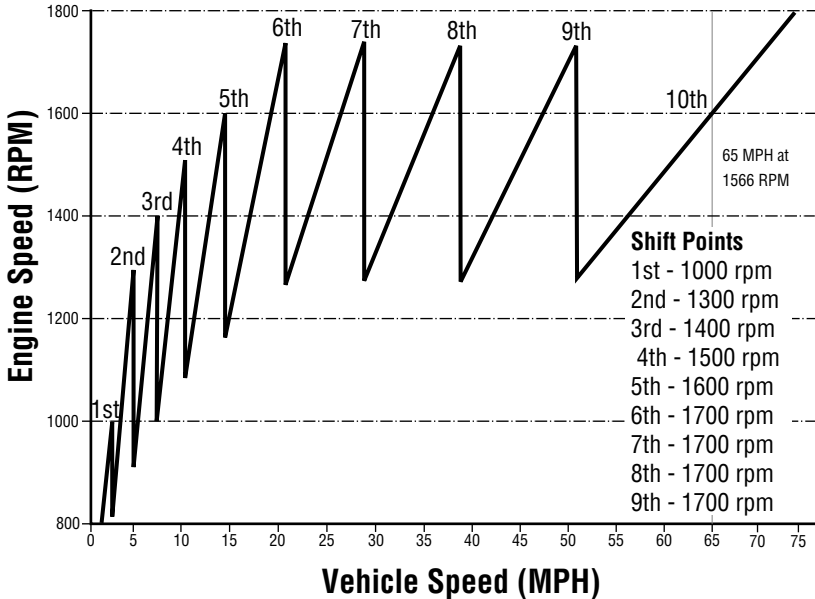

The example is based on a 1800 rpm governed engine, RTLO-14610B transmission, 3.90:1 rear axle ratio, and 275/80R24.5 tires.

**Note:** The transmission is shifted at less than the 1800 governed rpm. Also, progressive shifting is used in the lower gears to promote quicker transmission shifting and improved vehicle performance.

## **Reverse Operation**

The Super 10 has two usable reverse gear ratios. These two reverse ratios are selected by moving the shift button rearward (Low Reverse) or forward (High Reverse) when the gear shift lever is in the reverse position. For maximum vehicle control, Low Reverse is recommended for normal vehicle backing. For a faster vehicle speed when bobtail, high reverse can be used. Although, shifting between reverse ratios can be accomplished when the vehicle is moving, it is recommended that the vehicle be stopped when changing reverse ratios.

# Transmission Operation

## Range Shift

The auxiliary range shift automatically occurs between the center rail and the right rail. See illustration. This shift may be audible to the driver.

**IMPORTANT:** To avoid unnecessary wear and possible damage to the transmission, the shift lever should not be moved to the center or left rail position when the vehicle speed is greater than 40 MPH.

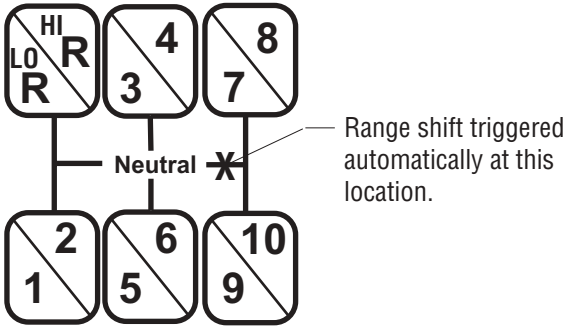

## Clutch Brake

Most heavy-duty trucks are equipped with a clutch brake.

A clutch brake stops the rotation of the clutch discs and transmission input gearing. It prevents the clashing or grinding of the gears when the vehicle is stationary and the driver is shifting from neutral into the starting gear.

A properly adjusted clutch brake will be activated when the driver fully depresses the clutch pedal. On a normal shift or when the vehicle is in motion, the driver must avoid activating the clutch brake to prevent transmission hard shifting and/or damage to the clutch brake.

## Countershaft Brake

Most heavy-duty trucks will occasionally use a countershaft brake system.

A countershaft brake also stops the rotation of the clutch discs and transmission input gearing. It prevents the clashing or grinding of the gears when the vehicle is stationary and the driver is shifting from neutral into the starting gear.

A countershaft brake is usually activated by a small button mounted onto the shift lever. The driver depresses this button when shifting from neutral to the initial starting gear. The clutch pedal must be depressed.



**CAUTION:** Damage can occur to the countershaft brake and the transmission if the button is depressed with the vehicle in motion or the clutch pedal not depressed.

# *Transmission Operation*

## How to get the most from your Super 10

### **Button only upshifts**

*BE PATIENT!* The transmission will only complete a shift when the engine RPM decreases to the level required for the next higher gear.

### **1st to 2nd upshift**

Perform the button shift to 2nd gear just after the vehicle has started in motion. This shift from 1st to 2nd gear can be accomplished at approximately 1000 RPM - even if fully loaded.

### **3rd to 4th button only shift on tight right turns**

Because of vehicle resistance created during the turn, either stay in 3rd gear through the turn, or shift into 4th before the turn.

### **Select the best starting gear**

If on level ground or lightly loaded, try starting in 2nd gear rather than 1st.

### **Use the vehicle tachometer**

Because newer vehicles and engines are quieter, it is harder to shift by "sound". Use the vehicle tachometer to determine when a shift completes.

## **Transmission Do's and Don'ts**

### **Do's**

- Do use normal Double-Clutching procedures when making lever shifts.
- Do preselect the shift button just prior to starting a shift.
- Do allow for the shift to complete by waiting for the engine speed to decelerate to the proper speed for the next desired gear.

### **Don'ts**

- Don't slam or jerk the shift lever into gear.
- Don't coast with the shift lever in the neutral position.
- Don't move the gear shift lever to the center or left rail position when the vehicle speed is greater than 40 mph.

# Super 10 Top 2

## Basic Operation and Overview of Super 10 Top 2

The Super 10 Top 2 transmission operates like a normal Super 10 in gears 1 through 8. The transmission shifts automatically between 9th and 10th gear based on engine speed and load.

When the transmission is in the Top 2 Mode, the system will:

- Shift the transmission between 9th and 10th gear automatically.
- Increase or decrease engine speed during a Top 2 shift.
- Momentarily interrupt cruise control or engine brake during the shift, then resume.

### Shift Pattern

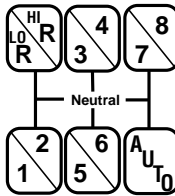

### Button Forward

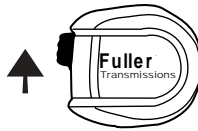

Shift 2, 4, 6, 8  
When button is forward

### Button Rearward



Shift 1, 3, 5, 7  
When button is rearward

## **Super 10 Top 2 Upshift Procedure**

1. Upshift the transmission through the shift pattern to 8th gear. Double-clutching during lever shifts and breaking torque during button shifts.
2. When the engine has reached the shift point use the normal double-clutching procedure and move the shift lever into 9th gear.

**Note:** The position of the shift button does not matter when moving the lever into the AUTO position. It is recommended to leave the shift button in the forward position so it is ready when you want to make a downshift into 8th gear.

3. When the engine has reached the shift point the transmission will automatically shift into 10th gear.

# *Super 10 Top 2*

## **Super 10 Top 2 Downshift Procedure**

1. To downshift from 10th to 9th gear:
  - a. Once the engine has reached the shift point the transmission will automatically downshift.
2. To downshift from 9th gear to 8th gear:
  - b. While in 9th gear, make sure the shift button is in the forward position.
  - c. Once the engine has reached the shift point move the lever to the next lower lever position while double-clutching.
3. Continue downshifting through the shift pattern, double-clutching during lever shifts and breaking torque during button shifts.

## **Super 10 Top 2 Driving Tips**

To activate Top 2 mode, the transmission must be shifted from 8th to 9th once the engine has reached the normal shift point. If the operator moves the shift lever into the AUTO lever position below the engines' normal shift point, the transmission will be in normal Super 10 mode. Once the engine reaches the normal shift point, Top 2 mode will become active.

Throttle position determines the upshift point. Less throttle will lower the shift point. Zero throttle (down hill push) will raise the upshift point. To reset the shift points the engine must drop below it's normal shift point.

With the engine brake active, the up and down shift points will be raised.

A feature of Top 2 is ANTI HUNT mode. This is built in to avoid constant up and down shifts. When the shift lever is in the AUTO position and the transmission has just completed an up shift, the down shift point will be lower than normal. If the transmission has just completed a down shift, the up shift point will now be higher than normal.

# *Super 10 Top 2*

## **Top 2 System Problem**

If the system malfunctions, the transmission will typically default to Super 10 mode. For some malfunctions, the system will detect a failure, that the operator must allow the Top 2 to time out. This will take 9 seconds. During the 9 seconds the Top 2 will try to complete the shift. Once the Top 2 has timed out the operator must place the transmission in neutral to obtain manual Super 10 mode. The Top 2 function will be inactive until the vehicle is stopped and the key is turned off.

In some situations, the system can be reset at a stop by leaving the key off for 10 seconds and then restarting the engine. If this does not clear the problem verify air pressure and check the fuse to the Top 2. To help assure operation of the Super 10 Top 2, advise your maintenance personnel of any oil leaks, above normal operating temperatures, unusual noises, fault codes, or if the transmission is not operating right.

## Lubrication Information

Proper lubrication procedures are the key to a good all-around maintenance program.

Eaton® Fuller® Transmissions are designed so that the internal parts operate in an oil circulating bath created by the motion of the gears and shafts.

All parts will be properly lubricated if these procedures are closely followed:

- Maintain oil level. Inspect regularly.
- Follow maintenance interval chart.
- Use the correct grade and type of oil.
- Buy from a reputable dealer.

## Maintain Proper Oil Level

Make sure oil is level with the filler opening. Being able to reach oil with your finger does not mean oil is at proper level. **(One inch of oil level is about one gallon of oil.)**

**When adding oil, never mix engine oils and gear oils in the same transmission.**

### Oil Level

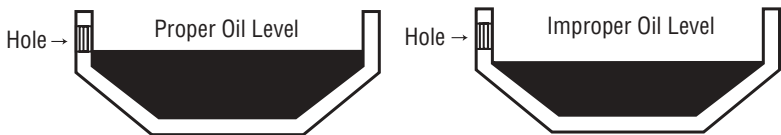

For additional lubrication information, see TCMT-0021.

# ***Service & Maintenance***

If your vehicle has a transmission oil filter, you must change the filter when fluid or lubricant is changed.

Additives and friction modifiers must not be introduced.

Never mix engine oils & gear oils in the same transmission.

The use of lubricants not meeting these requirements will affect warranty coverage.

For a list of Eaton Approved Synthetic Lubricants see TCMT-0020 or call 1-800-826-HELP (4357).

## **Buy from a reputable dealer**

For a complete list of approved and reputable dealers, write to:

Eaton Corporation  
**Truck Components**  
Global Marketing Services  
P.O. Box 4013  
Kalamazoo, MI 49003  
[www.roadranger.com](http://www.roadranger.com)

## **Transmission Operating Angles**

If the transmission operating angle is more than 12 degrees, improper lubrication will occur. The operating angle is the transmission mounting angle in the chassis plus the percent of upgrade (expressed in degrees).

For operating angles over 12 degrees, the transmission must be equipped with an oil pump or cooler kit to insure proper lubrication.

## Oil Cooler Information

Operating at temperatures above 250° F (120°C) causes loaded gear tooth temperatures to exceed 350° F (177°C) which will ultimately destroy the heat treatment of the gears. Temperatures above 250°F (120°C) should be regarded as a warning of inadequate cooling. If the elevated temperature is associated with unusual operating conditions that will reoccur, a cooler should be added, or the capacity of the existing cooling system increased.

The following conditions in any combination can cause operating temperatures of over 250°F:

- Operating consistently at slow speed.
- High ambient temperatures.
- Restricted air flow around transmission.
- Exhaust system too close to transmission.
- High horsepower operation.

External oil coolers are available to reduce operating temperatures when the above conditions are encountered.

## Oil Cooler Chart

Transmission Oil Coolers are:
Recommended
<ul style="list-style-type: none"><li>• With engines of 350 H.P. and above.</li></ul>
Required
<ul style="list-style-type: none"><li>• With engines 399 H.P. and above and GCW's over 90,000 lbs.</li><li>• With engines 399 H.P. and above and 1400 lbs. ft. or greater torque.</li><li>• With engines 450 H.P. and above.</li></ul>

# Service & Maintenance

## Preventive Maintenance

The following maintenance items are necessary to prevent costly transmission failures which may not be covered by warranty.

### Transmission Oil

- Check transmission daily for oil leaks. Repair promptly to prevent oil loss and subsequent transmission failure.
- Check transmission oil level at every engine oil change interval. Add transmission oil as necessary.
- Drain and replace transmission oil as recommended by the schedule in this book.

### Air System

- Drain moisture from vehicle air system daily.
- Listen for air leaks daily, repair promptly.
- If the vehicle is equipped with an air dryer, confirm that the air dryer system is working properly. Repair as necessary.
- Service the vehicle air compressor as required to prevent oil from entering the vehicle air system.

### Master Clutch System

- Lubricate clutch release pedal shaft bushings at every chassis lubrication interval. There should be one grease fitting on each side of the transmission clutch housing.
- Have the clutch checked and adjusted if any of the following occurs:
  - Clutch does not disengage completely
  - Clutch brake does not function, or
  - Clutch pedal free-play is less than 1/2".
- When replacing the clutch, use a high quality spring damped replacement unit.

## Drivetrain

- Inspect the driveshaft for loose or worn U-joints weekly. Repair promptly to prevent excessive driveline vibration.
- Have the driveline checked by a repair facility if unusual noise or vibration is detected.

## Overall Inspection

- Inspect the transmission at the chassis lubrication interval for loose or missing capscrews and fasteners. Pay particular attention to the capscrews that attach the transmission to the engine.

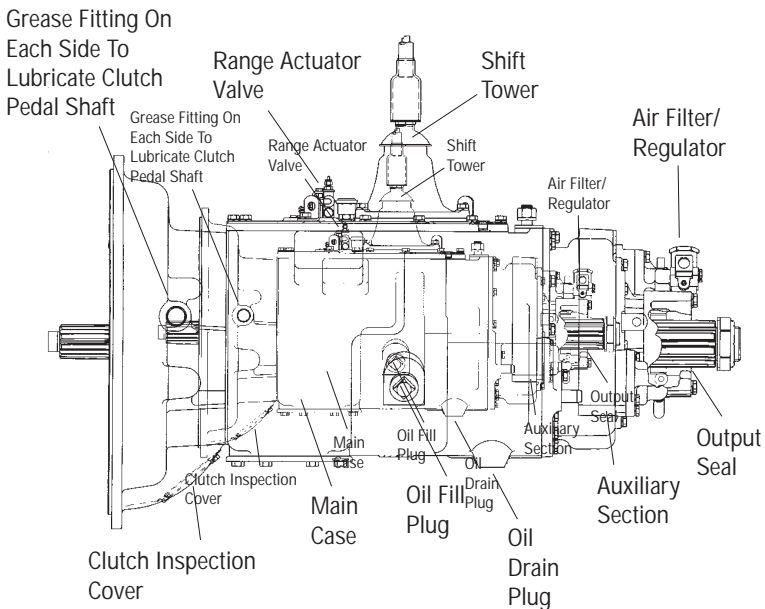

# Reference

## Definitions/Glossary of Terms for Transmission Operation

The following terms are used in describing the transmission operating procedures.

Break Torque	Releasing engine power or load from the transmission and drivetrain by releasing throttle or depressing clutch pedal.
Double-Clutch	The shifting technique used when moving the shift lever to the next lever position. Procedures: Depress clutch pedal, move lever to neutral, let up clutch pedal, accelerate or decelerate engine to obtain synchronous, depress clutch pedal again, and move lever into gear.
Preselect	Moving the shift button just prior to starting the shift. The shift button should not be moved while the shift lever is in neutral.
Ratio Step	Amount of change between two gear ratios expressed as a percentage. Example: The ratio step from 1st gear to 2nd gear is 35%.
Shift Button	The button on the side of the shift knob used to change gears.
Synchronous	The point at which the input gearing speed (engine speed) matches the output gearing speed (road speed) and a shift can occur without grinding.

## Definitions/Glossary of Terms for Super 10 Top 2

Auto Position	When the shift lever is in the position labeled "AUTO". This position is where 9th and 10th gears are located.
Top 2 Mode	The state where the transmission automatically shifts between 9th and 10th gears.



Copyright Eaton and Dana Corporation, 2007. EATON AND DANA CORPORATION hereby grants its customers, vendors, or distributors permissions to freely copy, reproduce and/or distribute this document in printed format. It may be copied only in its entirety without any changes or modifications. THIS INFORMATION IS NOT INTENDED FOR SALE OR RESALE, AND THIS NOTICE MUST REMAIN ON ALL COPIES.

# Roadranger®



©2007 Eaton Corporation and Dana Corporation  
All rights reserved. Printed in USA

For spec'ing or service assistance, call 1-800-826-HELP (4357) 24 hours a day, 7 days a week (Mexico: 001-800-826-4357), for more time on the road. Or visit our web site at [www.roadranger.com](http://www.roadranger.com)

Roadranger: Eaton, Dana and other trusted partners providing the best products and services in the industry, ensuring more time on the road.